

THE BEES ALGORITHM AND MECHANICAL DESIGN OPTIMISATION

D. T. Pham, M. Castellani, M. Sholedolu
Manufacturing Engineering Centre, Cardiff University, Cardiff, U.K.

A. Ghanbarzadeh
Mechanical Engineering Department, Engineering Faculty, Shahid Chamran University, Ahvaz, Iran

Keywords: Bees Algorithm, Optimisation, Mechanical Design.

Abstract: The Bees Algorithm is a search procedure inspired by the way honey-bees forage for food. A standard mechanical design problem, the design of a welded beam structure, was used to benchmark the Bees Algorithm against other optimisation techniques. The paper presents the results obtained showing the robust performance of the Bees Algorithm.

1 INTRODUCTION

Researchers have used the design of welded beam structures (Rekliatis et al., 1983) as a benchmark problem to test their optimisation algorithms. The welded beam design problem involves a nonlinear objective function and eight constraints. A number of optimisation techniques have been applied to this problem. Some of them, such as geometric programming (Ragsdell and Phillips, 1976), require extensive problem formulation; some (see, for example, (Leite and Topping, 1998)) use specific domain knowledge which may not be available for other problems, and others (see, for example, (Ragsdell and Phillips, 1976)) are computationally expensive or give poor results.

The Bees Algorithm has been applied to different optimisation problems (Pham et al., 2005, Pham et al., 2006b, Pham et al., 2006a). The design problems discussed in this paper are constrained optimisation problems to be solved using this new algorithm.

The remainder of the paper is structured as follows. Section 2 explains the main features of the foraging process and the steps of the Bees Algorithm. Section 3 describes the welded beam design problem. Section 4 presents the results obtained using the Bees Algorithm and other

optimisation procedures. Section 5 concludes the paper.

2 THE BEES ALGORITHM

2.1 The Foraging Process in Nature

During the harvesting season, a colony of bees keeps a percentage of its population as scouts (Von Frisch, 1976) and uses them to explore the field surrounding the hive for promising flower patches. The foraging process begins with the scout bees being sent to the field where they move randomly from one patch to another.

When they return to the hive, those scout bees that found a patch of a sufficient quality (measured as the level of some constituents, such as sugar content) deposit their nectar or pollen and go to the “dance floor” to perform a dance known as the “waggle dance” (Seeley, 1996). This dance is the means to communicate to other bees three pieces of information regarding a flower patch: the direction in which it will be found, its distance from the hive, and its quality rating (or fitness) (Von Frisch, 1976, Camazine et al., 2003). This information helps the bees watching the dance to find the flower patches without using guides or maps. After the waggle dance, the dancer (i.e. the scout bee) goes back to

the flower patch with follower bees recruited from the hive. The number of follower bees will depend on the overall quality of the patch. Flower patches with large amounts of nectar or pollen that can be collected with less effort are regarded as more promising and attract more bees (Seeley, 1996, Bonabeau et al., 1999). In this way, the colony can gather food quickly and efficiently.

2.2 The Bees Algorithm

This section summarises the main steps of the Bees Algorithm. For more details, the reader is referred to (Pham et al., 2006b, Pham et al., 2006a, Pham et al., 2005). Figure 1 shows the pseudo code for the Bees Algorithm. The algorithm requires a number of parameters to be set, namely: number of scout bees (n), number of sites selected for neighbourhood searching (out of n visited sites) (m), number of top-rated (elite) sites among m selected sites (e), number of bees recruited for the best e sites (nep), number of bees recruited for the other ($m-e$) selected sites (nsp), the initial size of each patch (ngh) (a patch is a region in the search space that includes the visited site and its neighbourhood), and the stopping criterion. The algorithm starts with the n scout bees being placed randomly in the search space. The fitnesses of the sites visited by the scout bees are evaluated in step 2.

-
1. Initialise population with random solutions.
 2. Evaluate fitness of the population.
 3. While (stopping criterion not met)
//Forming new population.
 4. Select sites for neighbourhood search.
 5. Determine the patch size.
 6. Recruit bees for selected sites (more bees for best e sites) and evaluate fitnesses.
 7. Select the fittest bee from each patch.
 8. Abandon sites without new information.
 9. Assign remaining bees to search randomly and evaluate their fitnesses.
 10. End While.
-

Figure 1: Pseudo code of the Bees Algorithm.

In step 4, the m sites with the highest fitnesses are designated as “selected sites” and chosen for

neighbourhood search. In step 5, the size of neighbourhood around the selected sites is determined. In step 6, the algorithm conducts searches around the selected sites, assigning more bees to search in the vicinity of the best e sites. Selection of the best sites can be made directly according to the fitnesses associated with them. Alternatively, the fitness values are used to determine the probability of the sites being selected. Searches in the neighbourhood of the best e sites – those which represent the most promising solutions – are made more detailed. As already mentioned, this is done by recruiting more bees for the best e sites than for the other selected sites. Together with scouting, this differential recruitment is a key operation of the Bees Algorithm.

In step 7, for each patch, only the bee that has found the site with the highest fitness (the “fittest” bee in the patch) will be selected to form part of the next bee population. In nature, there is no such a restriction. This restriction is introduced here to reduce the number of points to be explored. In step 8, sites which have not shown improvements in fitness values over a number of recruitment cycles are abandoned. This is because it is assumed that such sites correspond to stationary points. The locations of the sites are recorded. In step 9, the remaining bees in the population are assigned randomly around the search space to scout for new potential solutions.

At the end of each iteration, the colony will have two parts to its new population: representatives from the selected patches, and scout bees assigned to conduct random searches. These steps are repeated until a stopping criterion is met.

As described above, the Bees Algorithm is suitable for unconstrained optimisation problems. If a problem involves constraints, a simple technique can be adopted to enable the optimisation to be applied. The technique involves subtracting a large number from the fitness of a particular solution that has violated a constraint in order drastically to reduce the chance of that solution being found acceptable. This was the technique adopted in this work. As both design problems were minimisation problems, a fixed penalty was added to the cost of any constraint-violating potential solution.

3 WELDED BEAM DESIGN PROBLEM

A uniform beam of rectangular cross section needs to be welded to a base to be able to carry a load of 6000 *lbf*. The configuration is shown in Figure 2. The beam is made of steel 1010.

The length L is specified as 14 *in*. The objective of the design is to minimise the cost of fabrication while finding a feasible combination of weld thickness h , weld length l , beam thickness t and beam width b . The objective function can be formulated as (Rekliatis et al., 1983) :

$$\text{Min } f = (1 + c_1)h^2l + c_2tb(L + l) \quad (1)$$

where

f = Cost function including setup cost, welding labour cost and material cost;

c_1 = Unit volume of weld material cost = 0.10471 \$/*in*.³;

c_2 = Unit volume of bar stock cost = 0.04811 \$/*in*.³;

L = Fixed distance from load to support = 14 *in*;

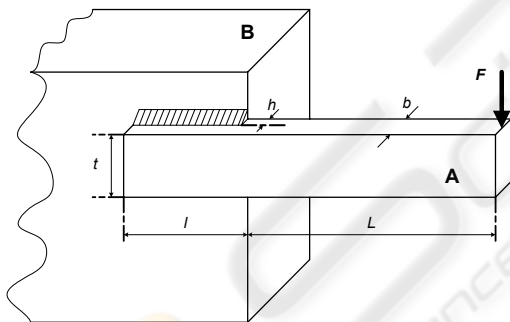

Figure 2: A Welded Beam.

Not all combinations of h , l , t and b which can support F are acceptable. There are limitations which should be considered regarding the mechanical properties of the weld and bar, for example, shear and normal stresses, physical constraints (no length less than zero) and maximum deflection. The constraints are as follows (Rekliatis et al., 1983):

$$g_1 = \tau_d - \tau \geq 0 \quad (2)$$

$$g_2 = \sigma_d - \sigma \geq 0 \quad (3)$$

$$g_3 = b - h \geq 0 \quad (4)$$

$$g_4 = l \geq 0 \quad (5)$$

$$g_5 = t \geq 0 \quad (6)$$

$$g_6 = P_c - F \geq 0 \quad (7)$$

$$g_7 = h - 0.125 \geq 0 \quad (8)$$

$$g_8 = 0.25 - \delta \geq 0 \quad (9)$$

where

τ_d = Allowable shear stress of weld = 13600 *Psi*;

τ = Maximum shear stress in weld;

σ_d = Allowable normal stress for beam material = 30000 *Psi*;

σ = Maximum normal stress in beam;

P_c = Bar buckling load;

F = Load = 6000 *lbf*;

δ = Beam end deflection.

The first constraint (g_1) ensures that the maximum developed shear stress is less than the allowable shear stress of the weld material. The second constraint (g_2) checks that the maximum developed normal stress is lower than the allowed normal stress in the beam. The third constraint (g_3) ensures that the beam thickness exceeds that of the weld. The fourth and fifth constraints (g_4 and g_5) are practical checks to prevent negative lengths or thicknesses. The sixth constraint (g_6) makes sure that the load on the beam is not greater than the allowable buckling load. The seventh constraint (g_7) checks that the weld thickness is above a given minimum, and the last constraint (g_8) is to ensure that the end deflection of the beam is less than a predefined amount.

Normal and shear stresses and buckling force can be formulated as (Shigley, 1973, Rekliatis et al., 1983):

$$\sigma = \frac{2.1952}{t^3b} \quad (10)$$

$$\tau = \sqrt{(\tau')^2 + (\tau'')^2 + (l\tau'\tau'')}/\sqrt{0.25(l^2 + (h+t)^2)} \quad (11)$$

where

$$\tau' = \frac{6000}{\sqrt{2hl}} \quad (\text{Primary stress})$$

$$\tau'' = \frac{6000(14 + 0.5l)\sqrt{0.25(l^2 + (h+t)^2)}}{2\left\{0.707hl\left(l^2/12 + 0.25(h+t)^2\right)\right\}}$$

(Secondary stress)

$$P_c = 64746.022(1 - 0.0282346t)tb^3 \quad (12)$$

4 RESULTS AND DISCUSSION

The empirically chosen parameters for the Bees Algorithm are given in Table 1 with the stopping criterion of 750 generations. The search space was defined by the following intervals (Deb, 1991):

$$0.125 \leq h \leq 5 \quad (13)$$

$$0.1 \leq l \leq 10 \quad (14)$$

$$0.1 \leq t \leq 10 \quad (15)$$

$$0.1 \leq b \leq 5 \quad (16)$$

With the above search space definition, constraints g_4 , g_5 and g_7 are already satisfied and do not need to be checked in the code.

Table 1: Parameters of the Bees Algorithm for the welded beam design problem.

Bees Algorithm parameters	Symbol	Value
Population	n	80
Number of selected sites	m	5
Number of top-rated sites out of m selected sites	e	2
Initial patch size	ngh	0.1
Number of bees recruited for best e sites	nep	50
Number of bees recruited for the other (m-e) selected sites	nsp	10

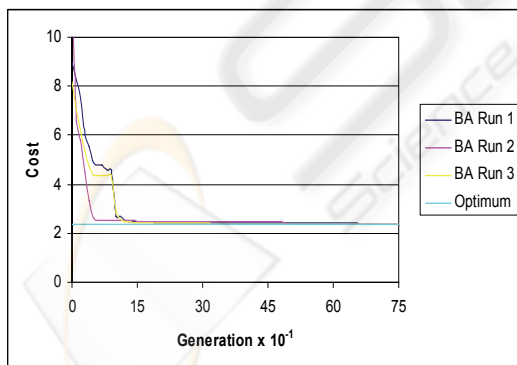

Figure 3: Evolution of the lowest cost in each iteration.

Figure 3 shows how the lowest value of the objective function changes with the number of iterations (generations) for three independent runs of the algorithm. It can be seen that the objective function decreases rapidly in the early iterations and then gradually converges to the optimum value.

A variety of optimisation methods have been applied to this problem by other researchers (Ragsdell and Phillips, 1976, Deb, 1991, Leite and Topping, 1998). The results they obtained along with those of the Bees Algorithm are given in Table 2. APPROX is a method of successive linear approximation (Siddall, 1972). DAVID is a gradient method with a penalty (Siddall, 1972). Geometric Programming (GP) is a method capable of solving linear and nonlinear optimisation problems that are formulated analytically (Ragsdell and Phillips, 1976). SIMPLEX is the Simplex algorithm for solving linear programming problems (Siddall, 1972).

As shown in Table 2, the Bees Algorithm produces better results than almost all the examined algorithms including the Genetic Algorithm (GA) (Deb, 1991), an improved version of the GA (Leite and Topping, 1998), SIMPLEX (Ragsdell and Phillips, 1976) and the random search procedure RANDOM (Ragsdell and Phillips, 1976). Only APPROX and DAVID (Ragsdell and Phillips, 1976) produce results that match those of the Bees Algorithm. However, as these two algorithms require information specifically derived from the problem (Leite and Topping, 1998), their application is limited. The result for GP is close to those of the Bees Algorithm but GP needs a very complex formulation (Ragsdell and Phillips, 1976).

5 CONCLUSIONS

A constrained optimisation problem was solved using the Bees Algorithm. The algorithm converged to the optimum without becoming trapped at local optima. The algorithm generally outperformed other optimisation techniques in terms of the accuracy of the results obtained. A drawback of the algorithm is the number of parameters that must be chosen. However, it is possible to set the values of those parameters after only a few trials.

Indeed, the Bees Algorithm can solve a problem without any special domain information, apart from that needed to evaluate fitnesses. In this respect, the Bees Algorithm shares the same advantage as global search algorithms such as the Genetic Algorithm (GA). Further work should be addressed at reducing the number of parameters and incorporating better learning mechanisms to make the algorithm even simpler and more efficient.

Table 2: Results for the welded beam design problem obtained using the Bees Algorithm and other optimisation methods.

Methods	Design variables				Cost
	h	l	t	b	
APPROX (Ragsdell and Phillips, 1976)	0.2444	6.2189	8.2915	0.2444	2.38
DAVID (Ragsdell and Phillips, 1976)	0.2434	6.2552	8.2915	0.2444	2.38
GP (Ragsdell and Phillips, 1976)	0.2455	6.1960	8.2730	0.2455	2.39
GA (Deb, 1991) Three independent runs	0.2489	6.1730	8.1789	0.2533	2.43
	0.2679	5.8123	7.8358	0.2724	2.49
	0.2918	5.2141	7.8446	0.2918	2.59
IMPROVED GA (Leite and Topping, 1998) Three independent runs	0.2489	6.1097	8.2484	0.2485	2.40
	0.2441	6.2936	8.2290	0.2485	2.41
	0.2537	6.0322	8.1517	0.2533	2.41
SIMPLEX (Ragsdell and Phillips, 1976)	0.2792	5.6256	7.7512	0.2796	2.53
RANDOM (Ragsdell and Phillips, 1976)	0.4575	4.7313	5.0853	0.6600	4.12
BEEES ALGORITHM Three independent runs	0.24429	6.2126	8.3009	0.24432	2.3817
	0.24428	6.2110	8.3026	0.24429	2.3816
	0.24432	6.2152	8.2966	0.24435	2.3815

ACKNOWLEDGEMENTS

The research described in this paper was performed as part of the Objective 1 SUPERMAN project, the EPSRC Innovative Manufacturing Research Centre Project and the EC FP6 Innovative Production Machines and Systems (I*PROMS) Network of Excellence.

REFERENCES

Bonabeau, E., Dorigo, M. & Theraulaz, G. (1999) *Swarm Intelligence: from Natural to Artificial Systems*, New York, Oxford University Press.

Camazine, S., Deneubourg, J.-L., Franks, N. R., Sneyd, J., Theraula, G. & Bonabeau, E. (2003) *Self-Organization in Biological Systems*, Princeton, Princeton University Press.

Deb, K. (1991) Optimal Design of a Welded Beam via Genetic Algorithm. *AIAA Journal*, 29, 2013-2015.

- Leite, J. P. B. & Topping, B. H. V. (1998) Improved Genetic Operators for Structural Engineering Optimization. *Advances in Engineering Software*, 29, 529-562.
- Pham, D. T., Ghanbarzadeh, A., Koc, E. & Otri, S. (2006a) Application of the Bees Algorithm to the Training of Radial Basis Function Networks for Control Chart Pattern Recognition. IN TETI, R. (Ed.) *5th CIRP International Seminar on Intelligent Computation in Manufacturing Engineering (CIRP ICME '06)*. Ischia, Italy.
- Pham, D. T., Ghanbarzadeh, A., Koc, E., Otri, S., Rahim, S. & Zaidi, M. (2005) Technical Report MEC 0501-The Bees Algorithm. Cardiff, Manufacturing Engineering Centre, Cardiff University.
- Pham, D. T., Ghanbarzadeh, A., Koc, E., Otri, S., Rahim, S. & Zaidi, M. (2006b) The Bees Algorithm, A Novel Tool for Complex Optimisation Problems. *2nd Int Virtual Conf on Intelligent Production Machines and Systems (IPROMS 2006)*. Oxford, Elsevier.
- Ragsdell, K. M. & Phillips, D. T. (1976) Optimal Design of a Class of Welded Structures Using Geometric Programming. *ASME Journal of Engineering for Industry*, 98, 1021-1025.
- Rekliatis, G. V., Ravindrab, A. & Ragsdell, K. M. (1983) *Engineering Optimisation Methods and Applications*, New York, Wiley.
- Seeley, T. D. (1996) *The Wisdom of the Hive: The Social Physiology of Honey Bee Colonies*, Cambridge, Massachusetts, Harvard University Press.
- Shigley, J. E. (1973) *Mechanical Engineering Design*, Ney York, McGraw-Hill.
- Siddall, J. N. (1972) *Analytical Decision-making in Engineering Design*, New Jersey, Prentice-Hall.
- Von Frisch, K. (1976) *Bees: Their Vision, Chemical Senses and Language*, Ithaca, N.Y., Cornell University Press.

