

# Flexinterface: A Framework to Provide Flexible Mobile Phone User Interfaces

## *Addressing the Elderly Diversity*

Vinícius P. Gonçalves<sup>1</sup>, Sibeliuss Seraphini<sup>1</sup>, Vânia P. A. Neris<sup>2</sup> and Jó Ueyama<sup>1</sup>

<sup>1</sup>*Institute of Mathematics and Computer Science, University of São Paulo, 13566-590, São Carlos-SP, Brazil*

<sup>2</sup>*Department of Computing, Federal University of São Carlos, 13565-905, São Carlos-SP, Brazil*

**Keywords:** Tailorable Interfaces, Flexibility, Cell Phone, Elderly, Middleware, Framework.

**Abstract:** This paper outlines our work to provide flexible smartphone interfaces targeting the elderly. Our research employs the Lancaster OpenCom middleware approach running on Android mobile phones. In this paper we present FlexInterface, an approach for a reconfigurable interface for elderly people and show how our model can help elderly people while interacting with mobile phones. We claim that flexible interfaces supports interaction in a more universal manner and in this paper we consider the elderly population. We carried out an assessment with the elderly to verify the feasibility of the proposal. The results suggest that there was a reduction in interaction time with the use of flexible interfaces and an increase in user satisfaction.

## 1 INTRODUCTION

According to the United Nations, there are currently 893 million people over the age of 60 in the world (United Nations, 2010). This number will nearly triple to 2.4 billion by the middle of this century. "All countries - rich or poor, industrialized or developing - are seeing their populations age in one degree or another", states the document (United Nations, 2010), adding that the elderly population growth will be faster than in other sectors of the population at least by the year 2050.

According to Nielsen (Nielsen, 2011), many elderly people in industrialized countries are active. Although they are usually retired, they lead a dynamic life and often have great interest in modern technologies, as for instance smartphones. This study also shows that 18% of the elderly use smartphones, and that there was a 6% increase in the purchase of these devices between 2010 and 2011.

However, many of today's design solutions for mobile phones target younger audiences, not including the elderly population (Czaja and Lee, 2007); (Gonçalves et al., 2011); (Wood et al., 2005), which has specific characteristics. Studies show a negative association between age and interaction skills (Hellman, 2007) and a significant reduction in

the number of people over 45 that benefits from today's Information and Communication Technologies (Minister of Industry, 2005).

Thus, it is necessary to provide interfaces that meet the highest possible number of elderly users, regardless of their sensory, physical, cognitive and emotional abilities. One way is to propose user interfaces that allow changes in their behavior during the interaction, giving each user the possibility to adapt the interface according to their preferences, needs and intended use (Neris and Baranauskas, 2012); (Gonçalves et al., 2010). In this context, flexibility refers to changes regarding the presentation of the interface elements, namely changes in color, size and window position, as well as changes in the order of the interaction actions.

It should be highlighted that although there are some studies in the literature regarding the flexible design applications on mobile phones for the elderly (Gonçalves et al., 2011); (Olwal et al., 2011); (Gonçalves et al., 2012), little is found on the implementation of these proposals. Therefore, this paper presents the FlexInterface, a framework that supports the development of tailored interface design can determine user profile based on the behavior pattern. Enabling to adapt the application to the user needs during interaction.

In order to verify the feasibility of this proposal given the various requirements of the elderly population (Gonçalves et al., 2011), an assessment was conducted with elderly people aged between 60 and 84. The sample group included persons with little education and higher education and different backgrounds regarding the use of technology.

This paper is organized as follows: Section 2 presents the OpenCom, an adaptive middleware which was used as the basis for developing FlexInterface; Section 3 presents the FlexInterface approach and evaluates the overload incurred by FlexInterface on a smartphone; Section 4 describes the design of flexible interfaces on mobile phones intended for the elderly and a case study of FlexInterface with older people and compares the results of a flexible approach with a non-flexible one. Section 5 presents the benefits of our approach and Section 6 presents the conclusion and suggests future works.

## 2 OpenCom MIDDLEWARE APPROACH FOR CONSTRUCTING FLEXIBLE INTERFACES

OpenCom (Ueyama et al., 2009) offers advantages over other middleware because it focuses on creating flexible systems in environments with scarce resources (e.g., low memory). It can also be used in heterogeneous environments, as will be discussed in more detail below. Other middleware, such as the Common Object Request Broker Architecture (CORBA), are not suitable to be used on mobile devices due to their robustness (Siegel, 1998). Moreover, CORBA is a software layer that requires memory resources that the platform of a cell phone does not have.

Another known approach is ReMMoC (Grace et al., 2003), which is a reflective middleware platform that dynamically adapts to support SLP (Veizades et al., 1997), and allows search and interaction with web services in a mobile environment. Thus, a mobile application can interact with a web service that makes use of the UPnP protocol (Microsoft Corporation, 2000), without considering how the implementation should be done.

Thus, as the scope of this research addresses middleware solutions for adaptive interfaces on mobile devices, a Middleware approach supported on OpenCom was defined, because this software layer supports dynamic adaptation, since the

application components can be reconfigured in running time. Therefore, depending on the needs of the system, the middleware adapts to the dynamic characteristics of the execution environment (Ueyama et al., 2009).

### 2.1 OpenCom Overview

OpenCom, besides being open source, has a flexible and extensible architecture, independent of language. It is based on a microkernel, where the features are incremented upon request (Ueyama et al., 2009).

OpenCom is a reflective and generic middleware that was developed at the University of Lancaster (Coulson et al., 2008), and it takes into account some characteristics, as outlined below:

**Domain Independence:** a general-purpose systems technology should provide only general and fundamental functions, which are independent of the needs of any particular domain. Thus, it is important that OpenCom builds generic software belonging to various domains such as: operating systems, middleware and embedded systems.

**Device Independence:** OpenCom is generic enough and allows creating software for a wide variety of platforms, such as PCs, set-top boxes and mobile devices with scarce resources – such as wireless sensor networks and mobile phones. This is achieved due to the use of microkernel and the possibility to add components with particular functions for each device.

**Low Overhead:** Due to the limited resources of some devices (for example: cell phones), it is necessary that the Kernel of OpenCom not only uses very little memory but also the minimum amount of other resources, such as CPU.

The components that provide the functions are responsible for performing the functions for which the application was developed. In a calculator, for example, the addition operation is a component, while the subtraction operation is another component. One component is not needed for the other to function, which allows the component that is not in use to be eradicated from the memory.

The components interact with other components in the capsule exclusively through interaction points, known as: “interfaces” and “receptacles” (Ueyama et al., 2009). Interfaces are service units provided by the components (Coulson et al., 2008). The components can support any number of interfaces. According to Coulson (Coulson et al., 2008), the receptacles are “required interfaces” that make explicit the dependencies of one component to other

components. The components can support any number of receptacles. Therefore, they are fundamental to support of other implemented modules and the construction of component-based software approach.

An OpenCom based application works on any device or operating system, provided it has the kernel of OpenCom ported to this device. Moreover, to ensure adaptability, the systems require the characteristics of each user, which can be acquired in various ways, from the registration data to the user navigation observed on the network system.

For this research the development of systems that adapt to various needs is highlighted; meeting the requests of different users, different devices and changes in environmental conditions. Given the aforementioned considerations, this study did not consider in its implementation only average needs, but primarily the differences, as described in the next section.

### 3 IMPLEMENTATIONS ISSUES

Using the set of rules that were defined in Section 3, for the design of flexible interfaces for elderly users, we developed a functional prototype which provides the interfaces that can adapt to the older public during run-time. The FlexInterface is a framework that assists in implementing flexible interfaces and was developed by means of Adaptive Middleware OpenCom. With the aid of this resource, it is possible to have mobile phone interfaces that adapt to different older- user profiles.

#### 3.1 The FlexInterface Approach

This research adopts a generic approach to build adaptive applications in mobile devices. Thus, (Ueyama et al., 2009) it shows that run-time reconfiguration is a key feature to handle the heterogeneous hardware that is inherent in mobile devices.

Thus, by defining the design of flexible interfaces so that they meet the many interaction requirements of the elderly with mobile phones (Gonçalves et al., 2011), it was possible to develop a software layer called FlexInterface based on the OpenCom component model (Ueyama et al., 2009).

FlexInterface is generic and has a flexible and extensible architecture that is not dependent on language. It is based on a microkernel, where the functions are incremented upon request. In this context, there is FlexComp, which is a generic and

reflective component of FlexInterface that has two receptacles called FlowScreen and ProfileChecker, as shown in Figure 1.

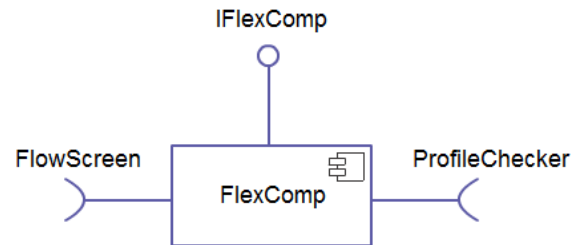

Figure 1: ElderlyFlex Component and its receptacles.

The FlowScreen component is responsible for storing the sequence of actions/screens that a given older user profile possesses, so that it can carry out a task in the device. Thus, with the FlowScreen it is possible, for example, to determine a sequence of specific screens, for older adults with a low level of education, to record a contact in the cell phone's agenda (Example: flow of actions / screens: Record Name > Record Phone > Save Contact).

Additionally, the ProfileChecker component receives the user's interaction data and on the basis of this information, is able to set the most appropriate type of profile, and then determine whether it is necessary to reconfigure the FlexInterface components.

#### 3.2 FlexInterface for Older Users

FlexInterface is a framework supported by the development of adaptive interface designs that allows the application to adapt to the needs of the user during his interaction with it.

With regard to the many requirements which emerged in the case study with the elderly and which led to a set of rules being defined for behavior-based adjustable interfaces (Gonçalves et al., 2011), two different profiles of elderly people were selected: seniors with up to fourth grade schooling (low education) and those with education beyond the fourth grade (high education).

Given the range of requirements, we used FlexInterface to provide adaptability to the interfaces. This meant that, as well as a change of actions/screen flow and of the interface elements, changes in the structure and size of the keyboard were also necessary. In view of this, the ElderlyFlex has been created, which is an extension of the FlexComp of the FlexInterface. This extension includes a new receptacle that is able to load the

keyboard component and is suitable for the profile determined by the ProfileChecker, as shown in Figure 3.

Thus, the keyboard is represented by three components to meet the requirements of elderly users: a) the default, b) for the elderly with low education and c) for the elderly with high education (DefaultKeyboard, LowEducationKeyboard and HighEducationKeyboard, respectively). Depending on how the user interacts with the application, the ProfilerChecker sets the most suitable profile at runtime and enables the ElderlyFlex to connect to the keyboard component that is most suited to the profile, as shown in Figure 2.

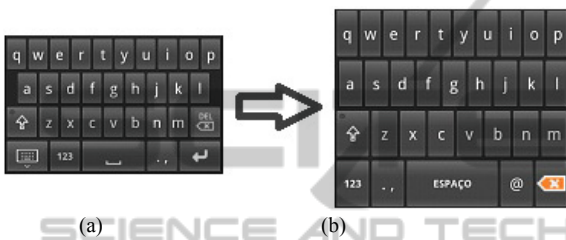

Figure 2: (a) Default Keyboard; (b) Adapted keyboard.

To determine which keyboard is best suited for each user profile Elderly collected the data from user input. For each keystroke, the following was collected:

- Given character
- Elapsed time (ms) from previous tap
- Error (when the user deletes a character)

With regard to the FlexInterface architecture, the components were developed that require the screen flow called FlowScreen. For this particular scenario, it was possible to explore the reconfiguration of the actions/screen flow. In this case, the ProfileChecker defines the interaction profile and analyzes the use of a new layout with a different action flow that can be used for the interface at the appropriate time.

Thus, owing to the change in the user’s standard interaction, in the scenario in which the default screens/actions flow component (DefaultFlow) is loaded the ProfilerChecker can, for example, set the low education as the most appropriate default for this older user. As a result, the default flow component will be disconnected and destroyed, freeing up the memory; following this, the screens/actions flow component for lower education (LowEducationFlow) will be created and connected to ElderlyFlex, making the application suitable for the new interaction default.

It should be noted that when the screens/actions flow reconfiguration is added, the screens of each flow establish the interface layout formatting, the position of the keys, the colors and the voice access, by strictly adhering to the rules defined by (Gonçalves et al., 2011) and using the PLuRaL framework.

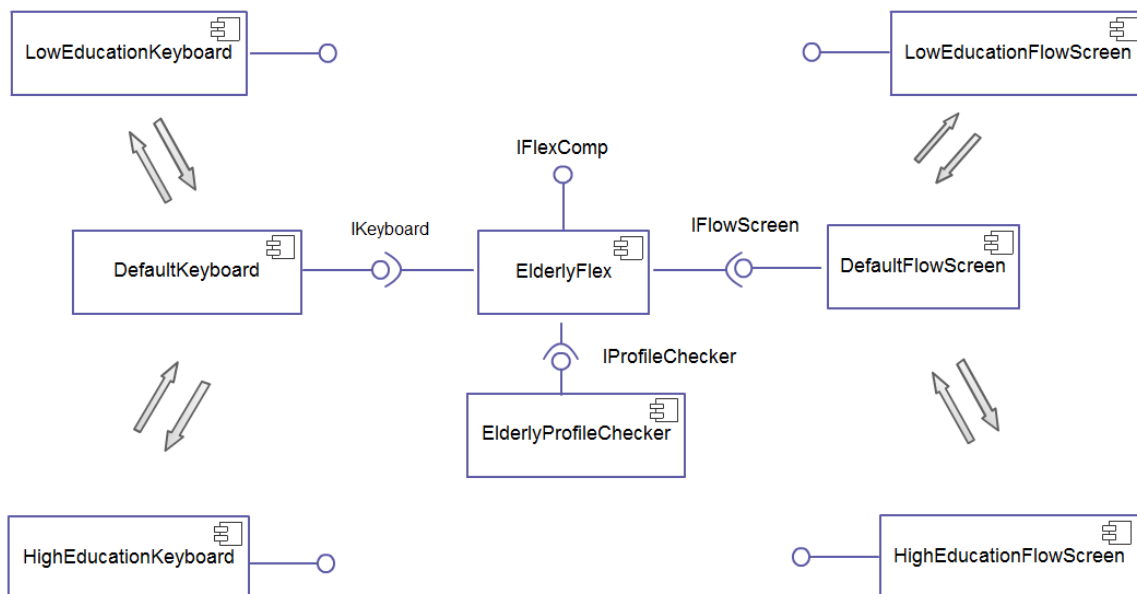

Figure 3: Our FlexInterface Components along with implemented Pluggable Extensions.

## 4 FLEXIBLE USER INTERFACE DESIGN FOR THE ELDERLY PEOPLE

The first results of this research report the outcomes of a case study with older users, in order to support the formalization of a flexible interface design for mobile phones to meet the interaction requirements of the elderly public (Gonçalves et al., 2011); (Gonçalves et al., 2011). The case study analyzed the application of a PLuRaL (Neris and Baranauskas, 2010) framework for the design of flexible interfaces and older users interacting with cell phones were observed.

This framework is organized in three pillars. The first one is to clarify the differences among the potential users, devices and environments in which the system can be used. Therefore, this step is to clarify the problem and identify possible solutions. The second pillar is the formalization of functional requirements, which is constructed upon a consistent view of the domain and that includes rules that oversee the users' behavior. Finally, the third pillar addresses an approach that defines the design of flexible interfaces through the formalization of standards for the tailored behavior of the system (Neris and Baranauskas, 2012).

Considering an approach that emphasizes the Universal Design (Connell et al., 1997), it is important to design systems that allow access to knowledge and information, without physical and social segregation and also that makes sense to the largest possible number of users according to their different sensory, physical, cognitive and emotional abilities. Thus, it is necessary to approach the elderly users and understand their peculiarities and interaction requirements in order to generate tailored interfaces that meet the preferences and needs of this target audience.

Therefore, unlike conventional applications, the development of a tailor-made system requires designers to consider in their interfaces the different potential uses, including the progress of users and their experience with technology.

In order to meet the many interaction requirements of the elderly public in a flexible approach that is aligned with the Universal Design principles (Connell et al., 1997), this paper adopted the PLuRaL as a reference to guide the design process and OpenCom to support the implementation of these flexible interfaces. However, perceiving that the literature emphasizes the interaction problems faced by elderly users and

brings little on the various requirements of this population of users, a practical observation activity was performed, to learn more about the interaction diversity of elderly users (Gonçalves et al., 2011).

The observation of the elderly corroborated with the characterization of the public in question, which guided and enriched the formal interaction requirements with mobile phones in six different aspects, starting with those regarding the physical aspect of the device, up to the impact of this interaction with the real world and the adjustable behavior of a cellular system to meet the interaction requirements of the elderly (Gonçalves et al., 2011).

In order to verify the FlexInterface proposal, a practical new observation activity was performed with a group of eight elderly people aged 60 and 84, schooling ranging from no education up to higher education (doctorate) and different experiences with the use of technology. Accordingly, the next subsections describe the planning and execution and formalizes some results derived from the observation.

### 4.1 Planning

Hypothesis: based on the different interaction requirements of the elderly with cell phones, we believe it makes sense to develop computing solutions that address the existence of specific situations, taking into consideration the standards defined by (Gonçalves et al., 2011) for the tailored behavior of the interfaces.

Purpose of the Case Study: observe and analyze elderly user interaction with smart phone flexible interfaces (smartphones) and verify if there is an interaction improvement, using as a parameter the practice carried out by (Gonçalves et al., 2011).

Methodology Applied: in order to analyze the elderly user interaction using mobile phone flexible interfaces, a senior user group was invited to participate in a practice using cell phones. The purpose of the activity was for the users to save a contact in the cell's phonebook and then place a call. With the data obtained in the observation, it was possible to see whether FlexInterface had facilitated the interaction.

Support Material: To conduct the case study, a Term of Consent, a Profile Survey Questionnaire and a Participant Observation Form were prepared. The Term of Consent elucidated the participants regarding the research objective, the voluntary participation and its scientific nature. The Profile Questionnaire Survey had social and cultural questions that allowed profiling these elderly users.

The Participant Observation Form was designed to help observe the user during his interaction with the cell phone. In addition, besides making use of the observation form, the participants were also being filmed, so that all the details of the study could be analyzed.

**Devices used:** The elderly people were organized into pairs and during each individual's interaction the pair received a Samsung Galaxy 5 with Android cell phone (smartphone) with OS version 2.2. The cell phone had the battery charged and with prepaid credits to make calls.

## 4.2 Execution

The observation practice of the elderly interacting with the cell phones took place in a Reference Center for Social Assistance (CRAS). These users are part of a group that performs physical activities intended for seniors, such as dance and theater. In parallel to these activities, eight people were invited to participate in some interaction tasks with the cell phones, as described below.

First, the users were profiled. Furthermore, users who did not have schooling, or never used cell phones, or just used them to answer calls could be identified. However, users with higher or secondary education besides making calls, also send messages, take pictures, edit contacts and play on their phones. It should also be noted that there was a user who had Alzheimer's, which according to the teacher of the group, was in an advanced stage.

For this application scenario a concept test that allowed adapting the interface to two user profiles was considered, defined by (Gonçalves et al., 2011): the elderly with low education (studied up to fourth grade), and educated elderly (studied beyond the fourth grade). It was correlated that the low education profile was characterized by having poor mobile phone experience.

The participants worked in pairs and each individual had a cell phone. The users profiles are as described in Table 1. During the test, the pair sat side by side during the cell phone interaction. Also, these users were shown a paper that had the name and phone number of a person they had to save in the cell's phonebook and then call the number in question.

While the users performed the task with the cell phone, the researchers conducting the case study filled out an observation form with questions such as: Needed help to start the task? The screen size is adequate for the items?

The elderly were also told that, if necessary, they

could help or ask for help from their partner. The number that was dialed was a landline number, which went to the answering machine, which repeated a message of thanks for their participation.

To define the pairs, an analysis of the profiles was performed that took into account age and education.

Table 1: Users profiles.

Pair	Users	Age	Education level	Cell phone usage
1	1, 2	81, 84	Less than 4 year	Never
2	3, 4	66, 60	Less than 4 year	Rarely
3	5, 6	60, 62	More than 12 years	Daily
4	7, 8	65, 69	Less than 4 year	Rarely

Therefore, people with similar ages and education levels were grouped together. After completing the task, the authors performed a discussion session with the pair, raising issues related to flexibility, the requirements met and the difficulties encountered during the cell phone interaction.

## 4.3 Observation Results

In this research approach it is important to emphasize that the evaluation was done at two different times and with users of similar profiles. Thus, the first evaluation focused on supporting the requirements gathered for the different elderly public and enable to evaluate the interaction time and user satisfaction in the commercial solution available in the cell phone used, that is with no flexibility. This first assessment is described in a previous work (Gonçalves et al., 2011). The second assessment verified the quality of flexible solutions for the elderly public, reported in this paper.

Taking into account the two practices conducted with elderly users interacting with smartphones, comparisons between the solutions presented could be established: interaction with flexibility and with no flexibility.

Therefore, from the observation, it was found that there is a reduction in the time to complete a task, in the flexible interfaces, when compared to the interaction time of the non-flexible proposal, as seen in Figure 4.

In line with the aforementioned, it was perceived that some of the Pair2 and Pair4 users declared: "I rather hear the voice than having to type."; "I loved talking to the cell phone. It talked to me!" and

“Telling the phone what it has to do is much easier. Is this phone for sale?”

Other users, those with low education, mentioned that the polychromatic interfaces facilitated their interaction with the device: “You can see that button well. I loved the color green!” Unlike what a user that has a doctorate declared:

“Having the color gray does not affect the task.”

This fact corroborates the survey conducted by (Gonçalves et al., 2011).

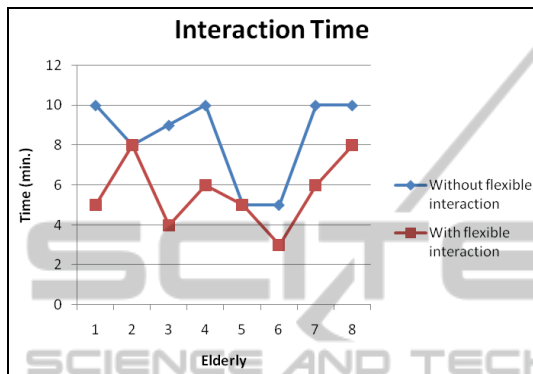

Figure 4: Interaction time.

Moreover, it is noteworthy for this survey the user satisfaction regarding the solutions presented in the assessment. Thus, it was possible to verify the satisfaction of these users, represented in the graph in Figure, through a survey that took into account favorable and unfavorable comments concerning the proposals. Therefore, comments like: “The cell phone vibrated right after I typed in the name. That was good!”, highlighted by a user of Pair1, considered as a favorable comment. However, for comments like the one by a member of the Pair2: “I click on the ‘A’ and an ‘S’ appears; the key is too small”, was considered as a negative comment.

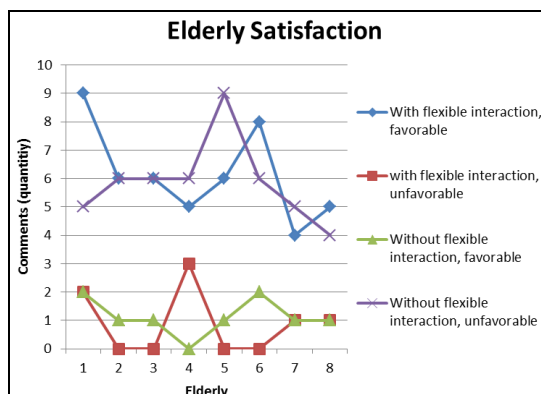

Figure 5: Graph showing elderly satisfaction.

Regarding the sequence of actions of a task, it

was observed that those with low education had a greater ease in performing the task and some of them, as for example, in the Pair4 pointed out: “I found the screens to save the name so easy and beautiful. My son’s cell phone isn’t like that!”

With the experiments with the elderly it was possible to infer that the use of FlexInterface in implementing the standards defined by (Gonçalves et al., 2011) largely met the needs and preferences of older users in the use of mobile phones.

## 5 BENEFITS OF OUR APPROACH

We present the potential benefits of adopting a generic approach to adaptive interfaces in the field of smartphones.

- *Adaptability and Extensibility.* The use of adaptive interfaces allows to modify the interface according to the individual needs of each user. The generic approach of FlexInterface allows new user profiles to be added to an application without the need to change the other components.
- *Transfer of Skills.* The use of different technologies to build applications for each device does not enable the transfer of skills through different tools. Set of skills and areas of expertise are rarely transferable when dealing with different technologies. The generic approach promotes the transfer of skills, given that developers use only a single tool for developing applications based on a variety of technologies.
- *Code reuse/modularity.* A generic approach promotes to reuse a code, hence developers can then reuse components. For example, in our approach the profile verification component for the Elderly (ElderlyProfileChecker) can be reused in other interfaces that will be used by the elderly.
- *Universal Design.* Our approach respects the different interaction needs and includes them in the design proposals. The FlexInterface framework considers a Universal Design approach (Connell et al., 1992), designed so that access to knowledge and information is made without physical and social segregation, and which makes sense to the largest possible number of users according to their different sensory, physical, cognitive and emotional skills.

## 6 CONCLUSIONS AND FURTHER WORK

This paper presented FlexInterface, a research that exploits the use of a middleware approach for constructing flexible interfaces. Thanks to the minimal kernel, FlexInterface is deployable on a

wide range of environments, including those with scarce resources (e.g. smartphones). We argue on our previous paper in (Gonçalves et al., 2011) that mobile phone interfaces are particularly designed for young people. This is a critical issue as the population of elderly people is increasingly higher, nowadays. We have shown the suitability of constructing a flexible interface using the runtime reconfigurable middleware approach that we borrowed from OpenCom. This ensures that both the young and the elderly people can make use of a single adaptive interface implementation on a smartphone. We have prototyped FlexInterface and carried out experiments with the elderly people on a Galaxy Samsung smartphone running Android.

In future work, we will better describe user behavior collecting a greater amount of user interaction data (touch screen clicks, keys, duration, etc.). This interaction detail will also allow an element of the screen to be reconfigured independently of the others. For example, if a user takes too long to click the Save key having already entered all the contact data, the interface resets the color of the key changes so that the user perceives what action he should do to finish the task.

Accordingly, the detailed behavior together with the reconfiguration of interface elements allows these interfaces to adapt to a wider range of features and skills of elderly users or not.

## REFERENCES

- Connell, B. R., Jones, M. Mace, R., et al.. About UD: Universal Design Principles. Version 2.0. Raleigh: The Center for Universal Design. [http://www.design.ncsu.edu/cud/about\\_ud/udprinciples.htm](http://www.design.ncsu.edu/cud/about_ud/udprinciples.htm).1997.
- Coulson G., Blair, G., Grace, P., et al.. A Generic Component Model for Building Systems Software. ACM Transaction on Computer Systems. 2008.
- Czaja, S. J., Lee, C. C. The impact of aging on access to technology. Universal Access in the Information Society. 2007.
- Gonçalves, V. P., Leite, B. C. S., Carvalho, J. R., et al.. Inspeção de Usabilidade: Um Processo Informatizado para Melhor Satisfazer os Objetivos do Usuário. In Anais da II Escola Regional de Informática, Manaus. 2010.
- Gonçalves, V. P., Neris, V. P. A., Morandini, M., et al.. Uma Revisão Sistemática sobre Métodos de Avaliação de Usabilidade Aplicados em Software de Telefones Celulares. In Anais do X Simpósio Brasileiro de Fatores Humanos em Sistemas Computacionais e V Congresso Latino-americano de Interação Humano-Computador, Porto de Galinhas. 2011.
- Gonçalves, V. P., Neris, V. P. A., Ueyama J. Interação de Idosos com Celulares: Flexibilidade para Atender a Diversidade. In Anais do X Simpósio Brasileiro de Fatores Humanos em Sistemas Computacionais e V Congresso Latino-americano de Interação Humano-Computador, Porto de Galinhas. 2011.
- Gonçalves, V. P., Neris, V. P. A., Ueyama, J., et al.. An Analytic Approach to Evaluate Flexible Mobile Phone User Interfaces for the Elderly. In Proceedings of 14th International Conference on Enterprise Information Systems, Wroław - Poland. 2012.
- Grace, P., Blair, G.S. and Samuel, S. ReMMoC: A reflective middleware to support mobile client interoperability. In Proceedings of the Symposium on Distributed Objects and Applications (DOA 2003, Catania, Sicily, Italy). 2003.
- Hellman, R. Universal Design and Mobile Devices. Proceedings of the 4th international conference on Universal access in human computer interaction: coping with diversity. Beijing. 2007.
- Microsoft Corporation, "Universal Plug and Play Device Architecture", Version 1.0, [http://www.upnp.org/download/UPnPDA10\\_20000613.htm](http://www.upnp.org/download/UPnPDA10_20000613.htm), June 2000.
- MT - Minister of Industry. Learning a Living - First Results of the Adult Literacy and Life Skills Survey. OECD, Paris. <http://www.nald.ca/fulltext/learnliv/learnliv.pdf>. 2005.
- Neris, V.P.A.; Baranauskas, M.C.C. Making interactive systems more flexible: an approach based on users' participation and norms. In Simpósio de Fatores Humanos em Sistemas Computacionais (IHC 2010): Belo Horizonte. 2010.
- Neris, V.P.A.; Baranauskas, M.C.C. Designing tailorable software systems with the users participation, 09/2012, Journal of the Brazilian Computer Society, Vol. 18, pp. 213-227, Rio de Janeiro, RJ, Brasil. 2012.
- Nielsen. J. Generation App: 62% of Mobile Users 25-34 own Smartphones. [http://blog.nielsen.com/nielsenwire/online\\_mobile/generation-app-62-of-mobile-users-25-34-own-smartphones](http://blog.nielsen.com/nielsenwire/online_mobile/generation-app-62-of-mobile-users-25-34-own-smartphones). 2011.
- Olwal, A., Lachanas, D., Zacharouli, E. OldGen: Mobile Phone Personalization for Older Adults. In: Conference on Human Factors in Computing Systems (CHI 2011), Vancouver. 2011.
- Siegel, J. OMG overview: CORBA and the OMA in enterprise computing, ACM. v41. n10. 1998.
- Ueyama, J., Pinto, V.P.V., Madeira, E.R.M., et al.. Exploiting a Generic Approach for Constructing Mobile Device Applications. In: The Fourth International Conference on COMMunication System softWare and middlewaRE, Dublin. ACM. 2009.
- Veizades, J., Guttman, E., Perkins, C., Kaplan, S. "Service Location Protocol", Internet RFC 2165, 1997.
- UN - United Nations. 'Major' rise in world's elderly population: DESA report. <http://www.un.org/en/development/desa/news/population/major-rise-in.html>. 2010.
- Wood, E., Willoughby, T., Rushing, A., Bechtel, L., Gilbert, J. Use of computer input devices by older adults. The Journal of Applied Gerontology. 2005.