

# Automated Driving System based on Roadway and Traffic Conditions Monitoring

Pavel Beresnev, Anton Tumasov, Dmitry Tyugin, Denis Zeziulin,  
Valery Filatov and Dmitry Porubov

*Nizhny Novgorod State Technical University n.a. R.E. Alekseev, Minina street, 24, Nizhniy Novgorod, Russian Federation*

**Keywords:** Automated Driving System, Advanced Driver-Assistance Systems, Lane Detection, Traffic Signs Detection, Obstacle Detection, Light Commercial Vehicles (LCV).

**Abstract:** In article development of a concept of advanced driver-assistance systems is considered. It consists of several subsystems such as a warning about leaving the line, warning the driver about the possibility of collision with an obstacle in the lane, detection of traffic signs. The concept of the system receives visual information about the road scene and decides on the need for to correct the course and speed parameters of the traffic. The component structure of system is shown. A number of methods are proposed (Hough Transform, bird's eye view, etc.) to solve the task. Tests of a concept of advanced driver-assistance systems are carried out. Based on the results of the tests, a technical task will be formulated for conducting development work.

## 1 INTRODUCTION

For many years, studies on advanced driver-assistance systems (ADAS) have been carried out to reduce the number of accidents and improve safety on the roads. The main algorithm of the advanced driver-assistance systems while driving is the collection of data from the sensors installed around the vehicle, further analysis of the information, detection of a critical situation on the road and conducting measures to avoid or mitigate the consequences

Currently the following ADAS are widely distributed: the lane departure warning system, obstacle detection system, traffic signs detection, parking assistant, pedestrian detection system, night vision system, adaptive cruise control, blind zone monitoring system etc.

The developed systems are widely used by automobile manufacturers. According to the statistics from Bosch GmbH (The journal modern electronics), the most common advanced driver-assistance systems are: the lane departure warning system (LDWS) and the advanced emergency braking system (AEBS). Moreover, unintentional departure from the occupied lane causes about 30% of all accidents on the road.

The development of ADAS is carried out by many large foreign automobile manufacturers. However, there are no own developments and solutions in the Russian Federation, which can be installed on vehicles in series. To implement the functions of ADAS on commercial vehicles adapted to the operational conditions in Russian Federation, the team of our university together with the GAZ Group is working on the concept of the advanced driver-assistance system on the GAZelle Next vehicle with the possibility to correct the vehicle's movement via the steering system.

At this stage the concept of the system consists of:

- Lane departure warning subsystem, defined by existing road markings;
- Driver warning subsystem, preventing the possibility of collision with an obstacle on the lane;
- Subsystem of traffic signs detection.

The concept of system should receive a stream of data from the front sensors (optical and/or infrared camera and thermal imager) for further processing.

The concept of the system receives visual information about the road scene and decides to adjust the parameters of the direction and the speed.

## 2 ANALYSIS OF ADAS

At the first stage of the development, an overview of information sources concerning the development of advanced driver-assistance systems has been performed.

In (Hoang, T., et al., 2016) a method for detecting road lanes was proposed, which distinguishes the dotted and solid lines of the road. Based on the experimental results with the Caltech open database, this method showed excellent results over traditional methods for detection road lanes.

The paper (Shanti B., and Ganorkar S., 2015.) shows the developing of an algorithm for a lane departure warning system. The system can be used successfully to reduce the number of road accidents that have occurred due to the sleepiness or inexperience of the driver. This paper shows the research and comparison of the available algorithms. Authors developed an algorithm for the image processing, which uses one camera installed on the vehicle. The stability of the algorithm has been tested in different conditions, such as lightning, shadows from adjoining building, vehicles etc. The algorithm is implemented in two stages. At the first stage, the algorithm finds the point of descent on the road, and then carefully selects the segments. The lines of the roadway were made by using information about the point of the road boundary. A heuristic filter was used to check and detect the road lanes. The Kalman's filter is used in order to track the road lane and processing the critical sections where the detection algorithm does not work.

The paper (Janda F., et al., 2013) is presenting a reliable real-time approach for determining the edges of roads by obtaining information from the radar and video camera. The road edge is defined as the transition from asphalt to off-road. The integration of the multi-lane detection system is shown, that makes this approach independent of the number of lanes and the visibility of the lane marks. System's performance is evaluated by using the reference data. Information about road geometry, curvature and the relative position of the vehicle is critical for advanced driver-assistance systems (ADAS). The detection of the road edge is the main component for proposed functions, such as preventing the crossing road edge, which keeps the vehicle on the under control area. This work is the part of the European project «interactiveIVe» that explores the new technologies and approaches to improving vehicle's safety via an integrated platform.

Paper (Pydipogu P., et al., 2013) describes the application of the IPM (Inverse Perspective Mapping) method. The system receives a video image by the camera installed on the vehicle, and then uses several processes to detect objects and road markings. A universal methodology was used to detect lanes and objects. A simple heuristic method was developed and it gives reliable results of detecting and tracking objects and lanes on a video stream. The heuristic method also gives effective results in the detection and tracking of several vehicles, regardless of distance.

An obstacle detection method based on moving cameras was developed in (Shah V., et al., 2016). This method was used to detect various obstacles (animals, traffic signs, obstacles, roadway irregularities), knowing the size of the roads. A new technique for detecting obstacles through moving cameras was proposed, that has several limitations in comparison with stationary cameras. The latest research trends were analyzed in this paper.

In the paper (Sumi K., and Arun Kumar M., 2017.) various methods of detection and recognition of traffic signs are explained. To detect the traffic signs and recognize their text, different methods are applied in order to get the desired accuracy. A comparative research of the methods is carried out and their effectiveness is explained. The authors of the paper suggest dividing the problem of detecting traffic signs into two stages. The first step is to find out the area of the desired traffic sign. The second stage is character recognition.

The system in (Fifik M., et al., 2010) is based on a two-stage traffic signs detection scheme. Input is the image that contains the information for extraction. A block called "Hypothesis Generation" (HG) generates promising hypotheses in the form of a Region of Interest (ROI). After this, the part called Hypothesis Verification (HV) checks or rejects the previously stated hypothesis. As the output, we have an image with ROI, which is recognized or determined during subsequent processing. This system can be divided into two subsystems. One subsystem is "fast", consisting of a CSR block and a classification block; the second is a "slow" subsystem consisting of image segmentation blocks, an invariant allocation function, functional memory, function modification, and type classification blocks. Also, experiments with this system were carried out. The average recognition speed of the system was 86% for the Hue, Saturation, Value (HSV) color area and 89% for the red, green, blue (RGB) color area. The best results achieved were 3-4 seconds for image processing.

Benchmarking of existing solutions in the area of advanced driver-assistance systems and autopilot motion was performed. As the comparative criteria a list of functions were defined:

- 1) Means of obtaining information;
- 2) Detection of the road marking;
- 3) Detection partially erased road marking;
- 4) Detection of the road edge;
- 5) System «follow me»;
- 6) Detection of vehicles moving towards;
- 7) Lane assist;
- 8) Night Vision System;
- 9) Movement in bad weather and road conditions (rain, snow, etc.);
- 10) Algorithms and method of functioning;

The objects of benchmarking were the world leaders of the development in the area of ADAS and unmanned ground vehicles. These are General Motors, Google, nVidia, Tesla, Volkswagen, Mercedes Benz, Baidu and others.

Regarding the first point of benchmarking almost all the manufacturers use cameras, it is also possible to use LIDARs and radars.

Vehicles of all companies are able to detect the road marking. But only General motors, Tesla and Volkswagen can detect partly erased road marking. Only General Motors, Google, nVidia, Baidu can detect the edge of the road.

To the fifth point of benchmarking list correspond the vehicles by Google, nVidia, Tesla, Volkswagen and Baidu. Also these vehicles are able to detect other vehicles moving towards.

The lane assist is realized practically at all companies, the big development of this system is realized at large automobile manufacturers, such as Volkswagen, Tesla and Mercedes Benz.

Advanced driver-assistance systems in all presented above vehicles are functioning at night. But in such bad road conditions as snow, rain, fog, best work performance is confirmed only by Google, nVidia, Tesla and Volkswagen.

By having considered information sources and carrying out benchmarking of existing solutions in the area of development of advanced driver-assistance systems, it was revealed that:

- At present, interest in developing or improving approaches to identifying obstacles, road lanes and signs is increasing (as evidenced by the large quantity of different articles in foreign sources).
- The use of cameras as a means of solving tasks is topical along with the growth of appropriate technologies.

- The use of cameras is the cheapest method of solving the problem of detection objects, lanes and road signs.
- Based on the conducted benchmarking, it can be concluded that the integration of advanced driver-assistance systems into vehicles of the largest automotive manufacturers has increased and large-scale research in this area of leading companies (Google, nVidia, Tesla, Volkswagen, Mercedes Benz, etc.) are carried out.

### 3 DEVELOPMENT OF ADAS FOR LCV

#### 3.1 Composition of ADAS

Based on the review of actual literature and benchmarking of advanced driver-assistance systems, the components of the concept of the lane detection system, the traffic signs detection and the obstacles detection on the road was determined.

As optoelectronic sensors, the Basler ace acA1300-200uc cameras are used. The location of the cameras is in the sides and in the middle of the windscreen. The video stream from the cameras is processed using the nVidia Jetson TX2 platform that has considerable computing power and small size that significantly affects the compactness of the entire system. Based on the analysis of driver assistance systems, video cameras are not sufficient for reliable and efficient operation of the entire recognition system. It is necessary to duplicate systems of recognition of the road scene by sensors that can function in difficult operating conditions, such as erased road lane, poor illumination of roads, presence of animals on the roadway, etc. In order to solve the above problems, it is proposed to use thermal imaging sensors in the system concept. The TITAN IP thermal imager is used in our system. A wide range of temperature exploitation allows it to function in snow, rain, fog and to recognize not only dynamic objects of the road scene (cars, pedestrians, animals), but also to determine the boundaries of the roadway and road markings. The structural scheme of interaction of the concept of the advanced driver-assistance systems is presented in Figure 1.

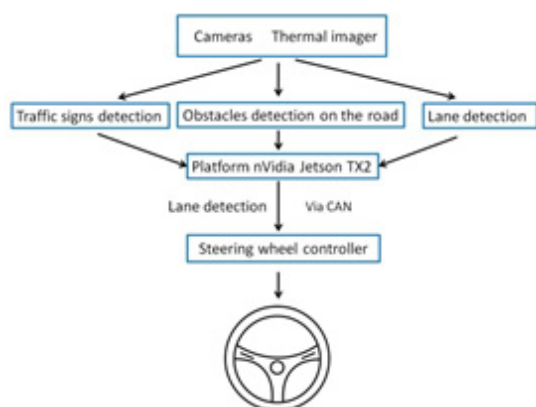

Figure 1: Structural scheme of the interaction of the driver-assistance systems.

### 3.2 Detection Method

There are many different approaches and methods for recognizing road lanes and road signs: B-spline model (Li W., et al., 2014, Deng J., et al., 2013); Hyperbola-pair lane model (Tan H., et al., 2014); Lane geometrical model (Zhou S., et al., 2010); Vehicle directional control model (DIRCON) (Litkouhi B., et al., 1993); Quadratic function model (Yoo H., et al., 2013); IPM model (Shin J., et al., 2014, Lu W., et al., 2014); Linear or parabolic model (Mu C., and Ma X., 2014.) etc.

Based on the results of the analysis of possible recognition methods, as well as taking into account the efficiency of computing power, two methods of recognizing road lanes and signs were chosen, this is the Haar Feature and the Hough Transform (Máthé K., and Buşoniu L., 2015). The use of these methods for solving the problem is compared.

Let us single out a number of criteria and compare the proposed methods.

#### Basis of the Method:

1. *Haar Feature*. The Viola-Jones method, wavelet, Haar primitives;

2. *Hough Transform*. In the simplest case, the Hough transform is a linear transformation to detect straight lines or boundaries.

#### Training:

1. *Haar Feature*. A database of images of the object sought in real-world conditions and a database of images without the desired object are needed. The cascade learns by examples, creating a set of rules for finding this object in xml format;

2. *Hough Transform*. No.

#### Identification Method

1. *Haar Feature*. In the entire matrix of the frame, it searches for a region suitable for a particular xml rule;

2. *Hough Transform*. The Hough's Transform algorithm uses an array called the accumulator to determine the presence of a direct (special case)  $y = mx + b$ . The dimension of the accumulator is equal to the number of unknown parameters of the Hough's area. Search is carried out by means of mathematical transformations.

#### Restrictions

1. *Haar Feature*. It is necessary to collect raw data directly at the target location of the detector. Any change in incoming data (changes in illumination, weather conditions, color characteristics, camera angle) adversely affects the result of detection. The algorithm is sensitive to the rotation angle of the sought object;

2. *Hough Transform*. The efficiency of the algorithm follows from the quality of the input data: the boundaries of the figures during the preprocessing of the image must be clearly defined. The use of Hough's transform on noisy images is difficult. For noisy images, a preprocessing step is required to suppress noise.

#### Advantage

1. *Haar Feature*. High speed of work, the ability to detect complex objects;

2. *Hough Transform*. High speed of work. It is possible the detection of simple geometric shapes.

Based on the analysis, the Hough Transform was chosen as the main algorithm for detecting traffic signs and lanes.

#### 3.2.1 Obstacles Detection on the Road

The TensorFlow Object Detection API is used, that allows creating and training object detection models based on neural networks to determine objects on the route,

The TensorFlow Object Detection API is an open source platform based on the TensorFlow library that allows you to create and training object detection models. The model is a set of files that contain information necessary for the recognition of certain objects. The finished model is the result of training of the neural network. Before training, a description file for detection objects is created, as well as set of data for each object on which the neural network will conduct its training. The training and debugging of neural network requires large computing power.

In the first stage (Figure 2), the obstacle detection system was tested on a video stream from a dash camera with a minimum number of obstacles (vehicles).



Figure 2: The first tests of the system on video files.

At the end of the first stage, the system was modernized and tested on a real road conditions. Figure 3 shows the frames tests of the system.

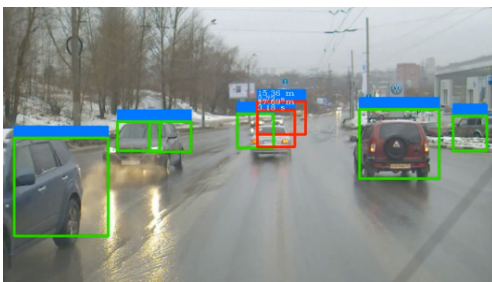

Figure 3: Example of system tests on a video stream of road conditions in the city of Nizhny Novgorod.

Upon completion of the system testing, a conclusion was made about the operability of this method.





### 3.2.2 Traffic Sign Detection

The system of automatic recognition of traffic signs is an important part of ADAS. It is designed to notify the driver of the presence of traffic signs on the road. The system can help the driver follow the speed limit established on the road section, observe travel restrictions, overtaking, etc.

Based on the chosen Hough Transform, the model of recognizing road signs on the roadway was developed. The development of the model was carried out with the open source library OpenCV (*OpenCV*: library) of computer vision algorithms, image processing and numerical algorithms for general purpose.

In order to design the algorithm, a number of traffic signs were used in accordance with the national standard of the Russian Federation №52290-2004 (National standard of the Russian Federation). The list of traffic signs is presented in Table 1.

Table 1: List of used road signs.

	
Crosswalk	The main road
	
No overtaking	Speed limit

This algorithm allows finding the necessary sign, only if it is available in the database.

For the operation of this algorithm, an image conversion circuit has been designed.

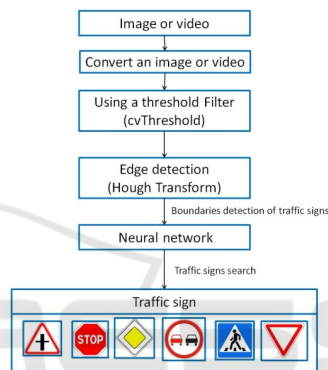

Figure 4: The image conversion scheme.

Based on this conversion scheme, a number of tests were carried out. Screen shots of the results are shown in Figure 5.



Figure 5: Screenshot of the system's output.

With regard to the recognition of road signs, the system showed an efficiency that meets the requirements, which is 96%, but it is necessary to expand the list of recognizable road signs for the most complete analysis of the road scene.

### 3.2.3 Lane Detection

The software of the road line detection system is based on the bird's eye view algorithm. Using this algorithm, with respect to solving the current task, allows you to display the selected section of the roadway in a distorted perspective. The scheme of this algorithm is shown in Figure 6.

As a region of interest (ROI), the trapezoidal image area is selected. This approach allows excluding unnecessary artifacts (untreated frame substrate) after a perspective distortion in the case of using a rectangular shape as the ROI.

By selecting the optimal parameters, an acceptable perspective view of the road section can be obtained. Then, there is a transformation of the image of ROI to the distorted perspective image.

To further process the resulting mapping, the matrix must be transferred from the RGB color space to the HSV color space. This space is less sensitive to light and shade changes in the frame, which allows increasing the stability of the algorithm on complex sections of the road.

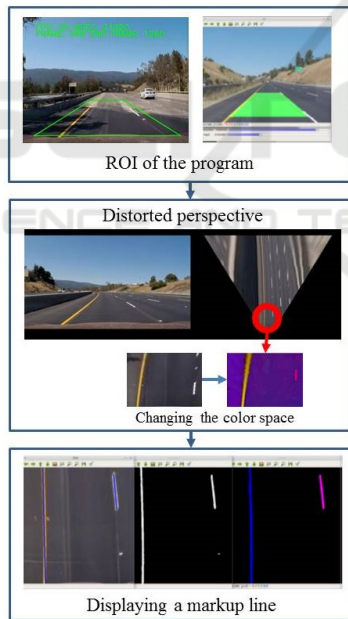

Figure 6: The scheme of the bird's eye view algorithm.

After the transition to the desired color space, the important preprocessing of image is binarization.

The purpose of binarization is to exclude from the frame all insignificant pixels that are not related to road markings (all pixels outside the color range of white and yellow markings).

To search for lines in the frame, the above-mentioned Hough transform is used.

When the function receives the binarized image of the prospective road as the input, it returns the vector of lines that can be used to identify the lines found in the frame.

After receiving a vector of lines, it is necessary to approximate all set in order to get one line corresponding to the position of the road line in the frame.

After carrying out virtual tests and optimizing the system for detecting road marking, an algorithm was further developed for warning about lane departure and tests were conducted in real road conditions.

The algorithm of the lane departure warning system is as follows. There are 3 warning zones: green - the car is in the center of the lane; yellow - deviation from the center of the lane is in the range from 0.2 to 0.3 m; red - deviation from the center of the lane is more than 0.3 meters (Figure 7-9).

During the tests, the car speed was about  $70 \pm 10$  km/h, entering the turn by a radius of curvature of at least 100 m and keeping the speed at a given level. After that the car performed a successive smooth approach to the road marking at a speed of 0.3 m/s. About 100 tests have been performed.

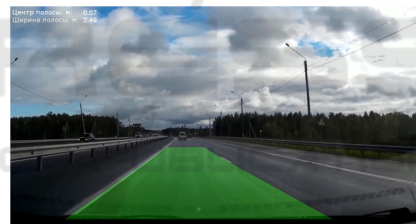

Figure 7: Example of the warning algorithm. Green zone.



Figure 8: Example of the warning algorithm. Yellow zone.

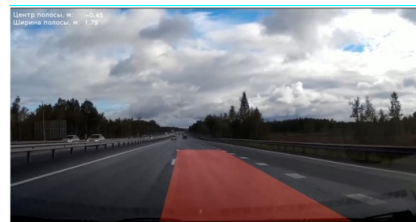

Figure 9: Example of the warning algorithm. Red zone.

The triggering did not happen, if in the process of making the vehicle closer to less than 30 centimeters with the line marking, no alert was given.

Based on the results of the tests, the following data were evaluated: the number of correct alarms when approaching the marking lines; the number of false alarms when approaching; number of failures when approaching.

The calculated accuracy of the recognition of marking lines was 0.76. The completeness, which shows the number of correct responses from the total number of real intersections of the road marking line, was 0.92. The indicator of the quality of the system was 84%.

### 3.3 Steering System

The developed concept of the system is planned to be installed on the GAZ Group's light commercial vehicles (*GAZ Group*).

GAZelle NEXT vehicles are equipped with a rack-and-pinion with a hydraulic booster steering system, which causes difficulties for the integration of advanced driver-assistance systems due to the cumbersomeness of the whole system and the complex technique of controlling the pump of the hydraulic system. Thus it was suggested to use a steering rack with an electric motor with the control capability. This steering rack shows similar strengths on the steering wheel that allows it to be used for GAZ Group commercial vehicles.

Based on the received and processed data from the lane detection system, the nVidia Jetson TX2 platform sends a signal to the steering controller with the electric motor via the CAN bus of the vehicle.

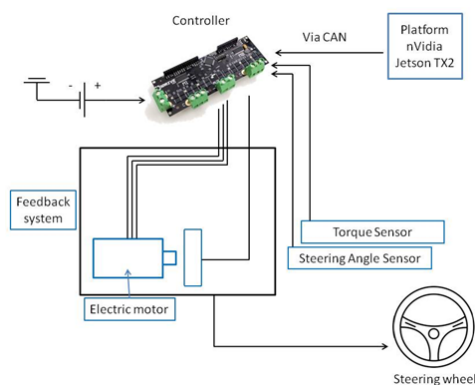

Figure 10: Steering system.

The controller controls the electric motor of the steering rack, sending the necessary signals via the

data bus. This method is the most secure and allows minimizing the possibility of losing control of the steering rack. The scheme of the system is shown in Figure 10.

Knowing the necessary distance to the side lane, the width of the lane and the width of the vehicle, the system is able to correct the movement of the vehicle, keeping it on the lane and does not allow to leave the lane.

## 4 CONCLUSIONS AND FUTURE WORK

Information sources were reviewed and benchmarking of existing solutions in the field of driver assistance systems, including autopilot technologies have been made.

Based on the analysis, the component composition of the concept system and the interaction scheme have been proposed.

Methods for solving the problem are proposed. The efficiency of the proposed methods was confirmed by a number of tests.

Combining systems for detecting road markings, signs, and obstacles along the way provides the opportunity to obtain the necessary information about the road scene in order to implement correct control actions on the steering mechanism.

The scheme of course orientation control by means of electromechanical system is developed. Timely impact of the electric motor through the servo-drive to the steering rack allows keeping the car in the lane, thereby increasing safety and reducing the probability of unintentional crossing of the lane.

At this stage of the project the structure of system of the ADAS-3 (SAE J3016) level is developed.

The problems in the technical implementation of the active steering system for light commercial vehicles of the GAZ Group have been solved.

The system works in various weather conditions and the heavy climate of the Russian Federation.

The next stage of the project is the development of design documentation for various vehicle systems, software and data transmission networks that integrate all subsystems into a single network in the on-board computer.

The prototype of the system concept will be installed on the GAZelle Next vehicle and examined at the GAZ Group's test site for debugging all of the components. Based on the results of the tests,

recommendations will be given in order to compile the Technical Assignment for development work.

## ACKNOWLEDGEMENTS

This research done with the financial support from Ministry of Education and Science of the Russian Federation in the frame of the complex project “The establishment of the high-tech manufacturing of safe and export-oriented GAZ vehicles with autonomous control systems and the possibility of integration with the electric platform on the base of components of Russian production” under the contract №03.G25.31.0270 from 29.05.2017 (Governmental Regulation №218 from 09.04.2010).

## REFERENCES

- Deng J., Kim J., Sin H., Han Y., 2013. Fast lane detection based on the B-spline fitting. *Int. J. Res. Eng. Tech.*, 2, 134–137.
- Fifik M., Turán J., Ovsenik L., Fazekas K., 2010. Experiments with a Transform based Traffic Sign Recognition System, *Proc. of 17th International Conference on Systems Signals and Image Processing IWSSI P2010*, pp. 227-230, June 17–19.
- GAZ Group. Retrieved October 30, 2017, from: <http://gazgroup.ru/>
- Hoang, T., Hong, H., Vokhidov, H., Park, K., 2016. Road Lane Detection by Discriminating Dashed and Solid Road Lanes Using a Visible Light Camera Sensor. *Sensors* 2016, 16, 1313.
- Janda F., Pangerl S., Schindler A., 2013. A Road Edge Detection Approach for Marked and Unmarked Lanes Based on Video and Radar, 16th International Conference on Information Fusion, July 9-12.
- Litkouhi B., Lee A., Craig D., 1993. Estimator and Controller Design for Lanetrak, a Vision-Based Automatic Vehicle Steering System. In *Proceedings of the 32nd Conference on Decision and Control*, San Antonio, TX, USA, 15–17; pp. 1868–1873.
- Li W., Gong X., Wang Y., Liu P., 2014. A Lane Marking Detection and Tracking Algorithm Based on Sub-Regions. In *Proceedings of the International Conference on Informative and Cybernetics for Computational Social Systems*, Qingdao, China, 9–10; pp. 68–73.
- Lu W., Rodriguez F., Seignez E., Reynaud R., 2014. Monocular Multi-Kernel Based Lane Marking Detection. In *Proceedings of the 4th Annual International Conference on Cyber Technology in Automation, Control, and Intelligent Systems*, Hong Kong, China, 4–7; pp. 123–128.
- Máthé K.; Buşoniu L., 2015. Vision and Control for UAVs: A Survey of General Methods and of Inexpensive Platforms for Infrastructure Inspection. *Sensors* 2015, 15, 14887-14916.
- Mu C., Ma X., 2014. Lane detection based on object segmentation and piecewise fitting. *TELKOMNIKA Indones. J. Electr. Eng.*, 12, 3491–3500.
- NATIONAL STANDARD OF THE RUSSIAN FEDERATION №52290-2004 Traffic control devices. Traffic signs. General technical requirements.
- On-road Automated Vehicle Standards Committee, 2014. SAE J3016: Taxonomy and Definitions for Terms Related to On-Road Motor Vehicle Automated Driving Systems. SAE International.
- OpenCV library. Retrieved October 30, 2017, from: <https://opencv.org/>
- Pydipogu P., Fahim M., Shafique M., 2013 Robust lane detection and object tracking In relation to the intelligence transport system. Master’s Thesis Electrical Engineering Signal Processing.
- Shah V., Maru S., Jhaveri R., 2016. An Obstacle Detection Scheme for Vehicles in an Intelligent Transportation System, *Int. J. Comput. Netw. Inf. Secur.*, vol. 8, no. 10, pp. 23–28.
- Shanti B., Ganorkar S., 2015. Real-Time Lane Detection for Driving System Using Image Processing. *International Research Journal of Engineering and Technology (IRJET)*, Volume: 02 Issue.
- Shin J., Lee E., Kwon K., Lee S., 2014. Lane Detection Algorithm Based on Top-View Image Using Random Sample Consensus Algorithm and Curve Road Model. In *Proceedings of the 6th International Conference on Ubiquitous and Future Networks*, Shanghai, China, 8–11; pp. 1–2.
- Sumi K., Arun Kumar M., 2017. Detection and Recognition of Road Traffic Signs - A Survey. *International Journal of Computer Applications (0975 - 8887)*, Volume 160 - No.3.
- Tan H., Zhou Y., Zhu Y., Yao D., Li K., 2014. A Novel Curve Lane Detection Based on Improved River Flow and RANSA. In *Proceedings of the International Conference on Intelligent Transportation Systems*, Qingdao, China, 8–11; pp. 133–138.
- The journal modern electronics. Retrieved October 30, 2017, from: <https://www.soel.ru/rubrikator/rynok/>
- Yoo H., Yang U., Sohn K., 2013. Gradient-enhancing conversion for illumination-robust lane detection. *IEEE Trans. Intell. Transp. Syst.*, 14, 1083–1094.
- Zhou S., Jiang Y., Xi J., Gong J., Xiong G., Chen H., 2010. A Novel Lane Detection Based on Geometrical Model and Gabor Filter. In *Proceedings of the IEEE Intelligent Vehicles Symposium*, San Diego, CA, USA, 21–24; pp. 59–64.